

Lesson 6: Terminal Voltage

Terminal Voltage is the voltage (potential) difference between the ends of a battery or cell. The ends or posts of a battery are called terminals. A cell contributes some resistance to a circuit; this is called the **internal resistance** of the cell.

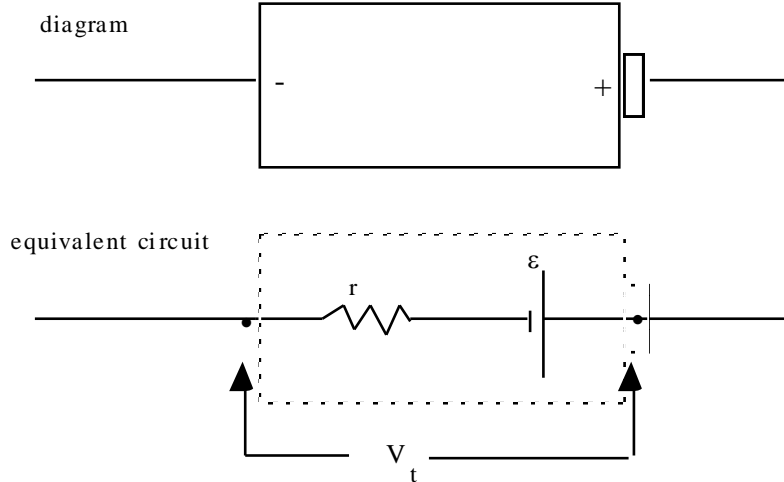

I = current through cell

r = internal resistance of the cell

ϵ = internal/chemistry voltage (sometimes called emf)

V_t = external/net/terminal voltage

• = battery terminal

Ex. 0) Suppose this battery has an emf of $\epsilon = 36 \text{ V}$, and an internal resistance $r = 0.20 \text{ }\Omega$.

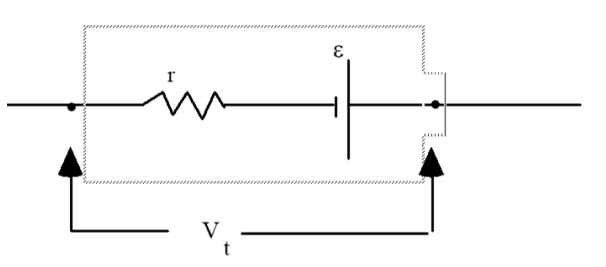

What is the terminal voltage if

a) a current of 12 A is running through the battery

b) a current of 8.0 A is running through the battery

c) A current of 140A is running through the battery

•in the ski hill analogy, internal resistance is like the ramp at the top of the chairlift. As part of the ride to the top(cell) , there is inevitably a bit of height loss on the ramp (voltage drop across the internal resistor).

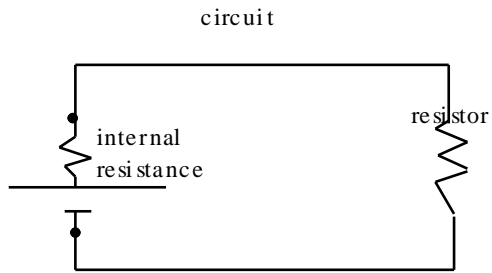

power supply
battery
cell

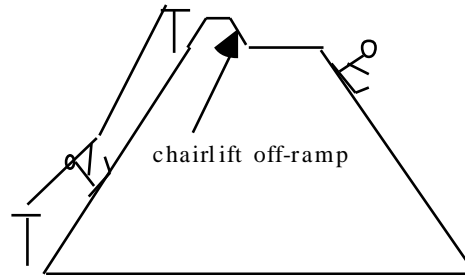

ski hill analogy

•example 1: what happens to the cell voltage (measured by the voltmeter) if we close the switch? (so that the current drawn by the circuit increases)

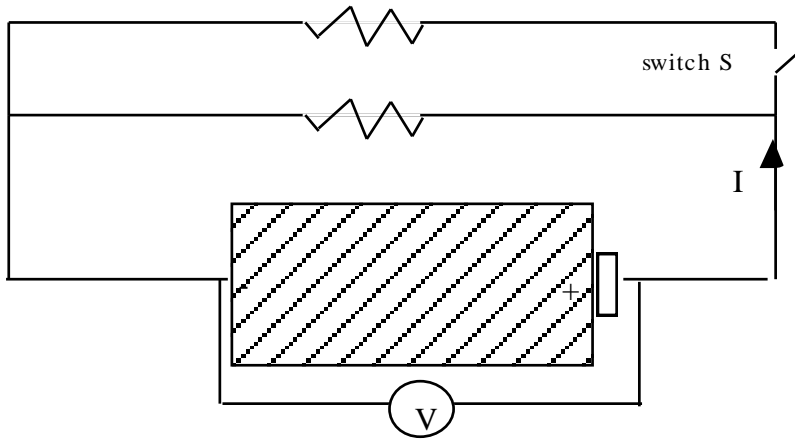

- a) no change b) increases c) decreases

explain your answer using relevant concepts of physics

•example 2: find an expression for the terminal voltage

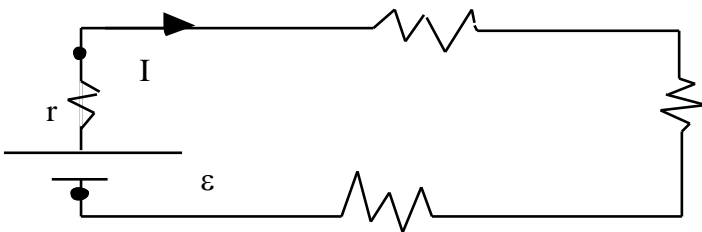

•example 3: find the terminal voltage, then find the power used by the 30 Ω resistor

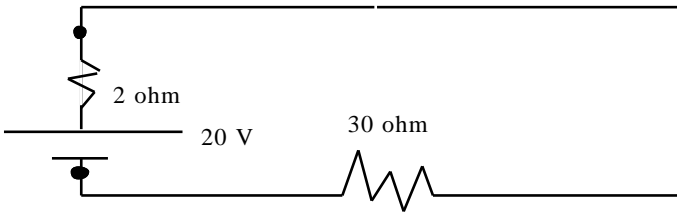

•example 4: find the terminal voltage and the internal resistance

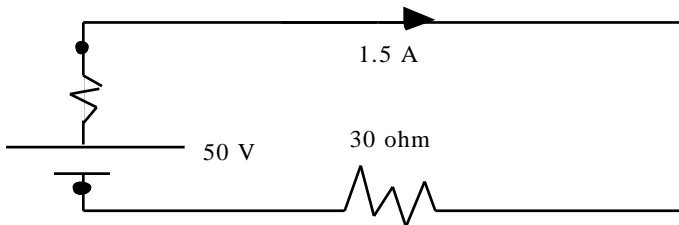

Ex. 5)

The battery in the diagram below is delivering a current of 2.0 A.

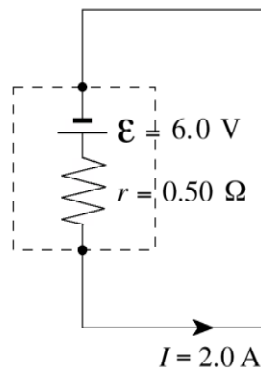

What will be the reading on a voltmeter connected to the battery terminals?

- A. 1.0 V
- B. 5.0 V
- C. 6.0 V
- D. 7.0 V

Ex. 6) Find the total resistance, total current, and terminal voltage of the circuit below:

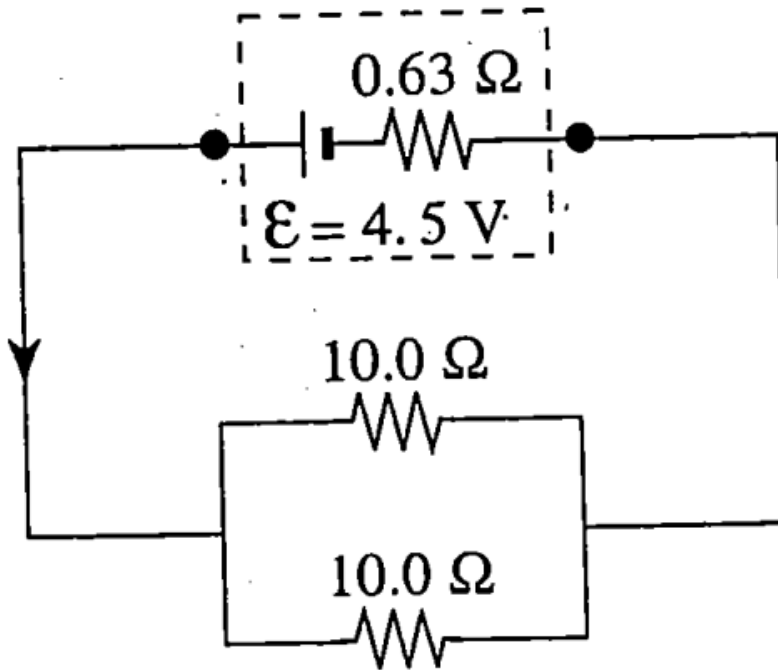

•in summary :

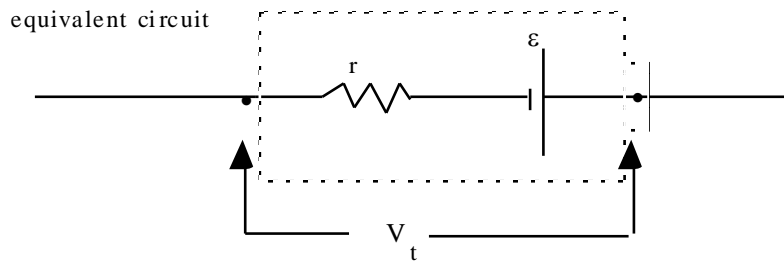

supply $V_t =$

$I =$ current through cell

$r =$ internal resistance of the cell

$\epsilon =$ internal/chemistry voltage (sometimes called emf)

$V_t =$ external/net/terminal voltage

•=battery terminal

Lesson 6 Homework

1. Find the terminal voltage of a 6.0 volt cell with $0.60\ \Omega$ internal resistance that is connected to a $7.2\ \Omega$ load
(5.53 V)

2. Four 1.50 V cells are connected in series in the same direction inside a flashlight. If the internal resistance of each cell is $0.400\ \Omega$ and the light bulb has resistance $6.20\ \Omega$ then find the current through the bulb and the terminal voltage of each cell. (0.769 A; 1.19 V)

3. A 1.5 V dry cell is short circuited and produces a maximum current of 30. A. At this current, the terminal voltage is zero. What is the internal resistance of the cell? (0.050 Ω)

4. A 12.0 volt cell has 8.8 V terminal voltage when it is providing 70.A of current. What is the internal resistance of the cell? (0.045 Ω)

7. find the total current in this circuit when the switch(S) is

a) open b) closed (1.9 A; 5.2 A)

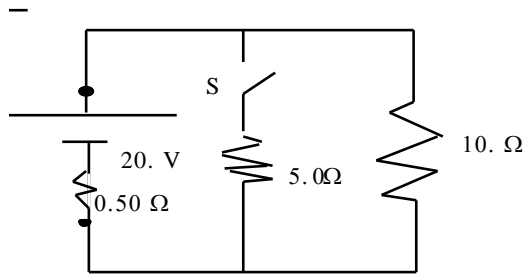

8. find the total current in this circuit when the switch(S) is

a) open b) closed (1.9 A; 40. A)

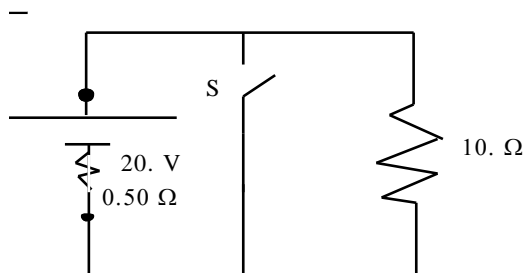

9. Find R_t and I_t then all voltages and currents

($50\Omega, 2.0A$; $20.V, 2.0A$; $20V, 0.67A$; $20.V, 1.3A$; $60.V, 1.5A$; $60.V, 0.50 A$)

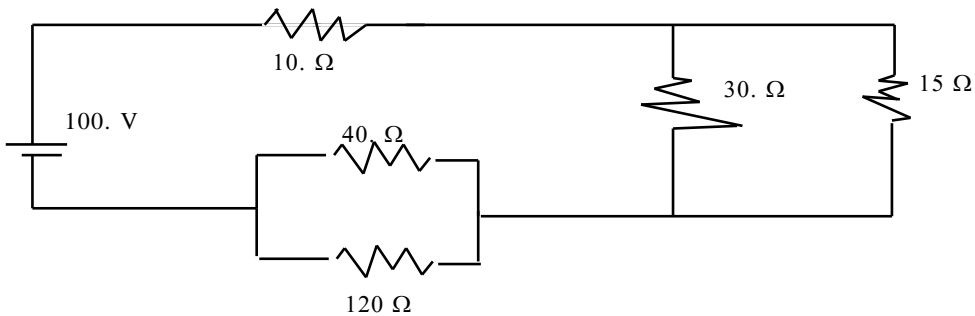

10. Find the cell voltage given that 2.00A flows through the 15.0Ω. (225V)

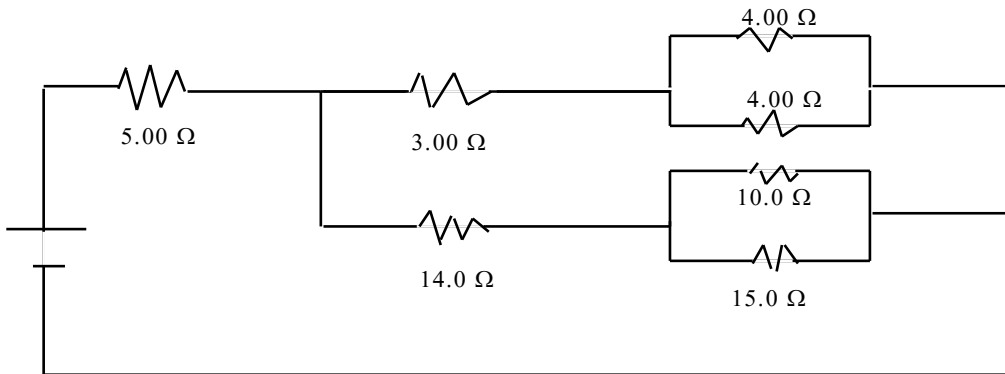

11. Find the unknown voltage drops and currents

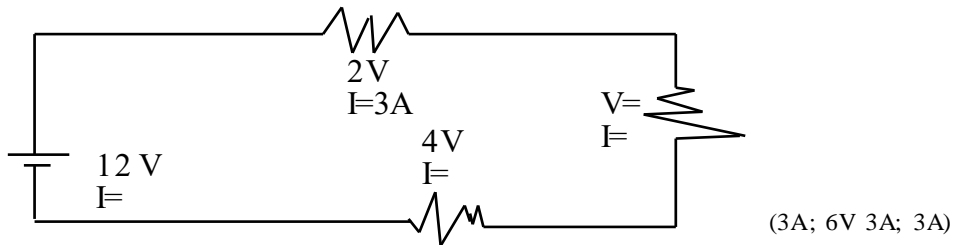

12. Find the total current on a 120. volt household circuit if we plug in a 1200. W toaster and a 60.0 Watt light bulb (10.5 A)

13.

The current through the 50.0Ω resistor in the circuit below is 0.14 A.

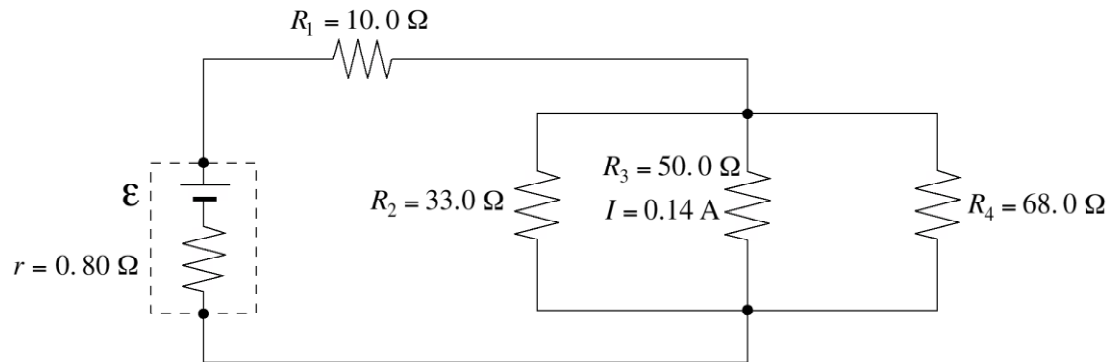

- a) Determine the emf of the battery. (5 marks)
- b) Determine the power dissipated in the battery's internal resistance. (2 marks)

14.

In the following circuit, what is the terminal voltage of the battery?

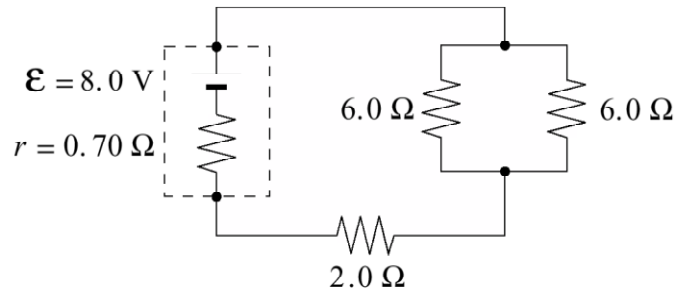

- A. 6.9 V
- B. 7.0 V
- C. 8.0 V
- D. 9.0 V

15.

a) Find the value of resistor R_2 .

(5 marks)

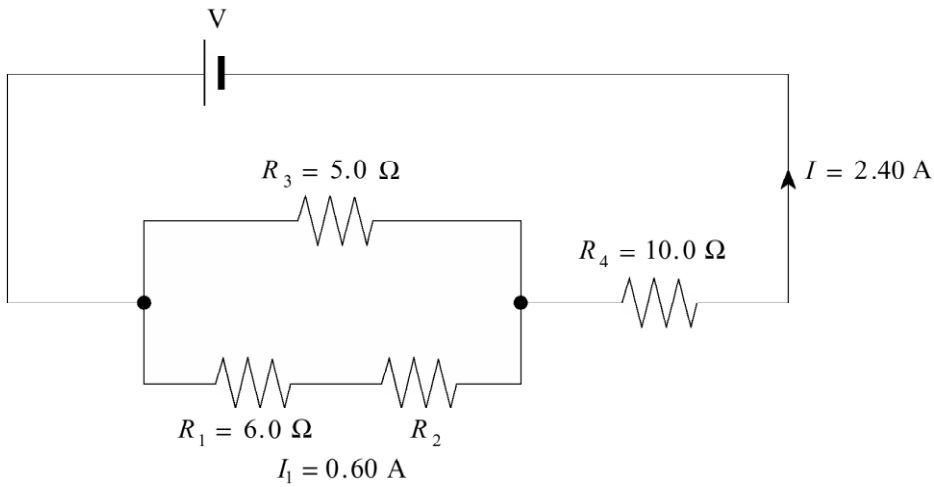

b) Find the potential difference of the power supply, V .

(2 marks)

16.

The cell shown in the diagram supplies a 1.80 A current to the resistors R_1 and R_2 .

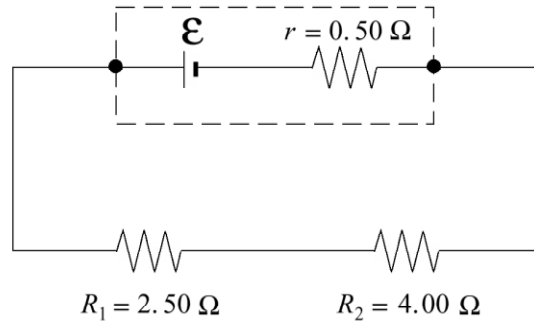

a) What is the terminal voltage of the cell?

(3 marks)

b) What is the emf of the cell?

(4 marks)

17.

The circuit shown in the diagram below consists of a 9.00 V battery and a 3.50 W light bulb.

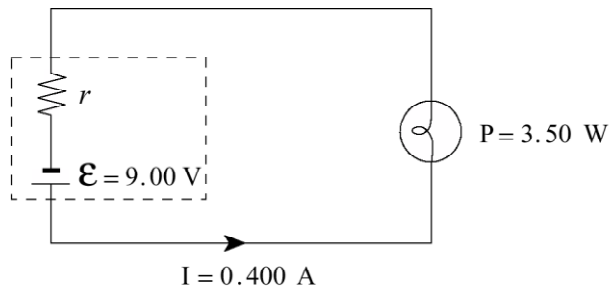

a) If a current of 0.400 A leaves the battery, what is the internal resistance, r , of the battery?

(5 marks)